

The SL Roadster



Mercedes-Benz



This special wonderment is in the air again.

SL – initials with a rare power to unleash a rush of euphoria. Allow yourself to be inspired by an iconic design that celebrates present-day open-air luxury and sportiness. A legendary sports car tradition, dynamically transported into the present time with the latest suspension technology. The new-generation SL.

SENSATIONAL IN EVERY FORMAT.



Experience the SL in thrilling HD. With the Mercedes-Benz brochure app for the iPad® and with the Digital Owner's Manual from "Mercedes-Benz Guides" for the iPhone®. Both apps feature a host of films and additional content and are available free of charge from the iTunes Store®.

The finest faces of an icon.

2 | Mercedes-Benz SL 500

brilliant blue metallic

AMG Line design and equipment line, AMG multi-spoke light-alloy wheels, Exclusive nappa leather upholstery in porcelain/black, high-gloss black ash trim

14 | Mercedes-Benz SL 400

selenite grey metallic

5-spoke light-alloy wheels, Exclusive nappa leather upholstery in black, light carbon-grain aluminium trim

56 | Mercedes-AMG SL 63

designo diamond white bright

AMG Exterior Carbon-Fibre package, AMG cross-spoke forged wheels painted matt black and with high-sheen rim flange, black Exclusive nappa leather upholstery, AMG carbon-fibre trim

66 | Mercedes-AMG SL 65

brilliant blue metallic

AMG 10-spoke ceramically high-gloss-polished light-alloy wheels, Exclusive nappa leather upholstery in ginger beige/espresso brown, AMG carbon-fibre trim

The innovative faces of an icon.

24 | Mercedes me connect

28 | Services

32 | Engines

33 | Automatic transmission 9G-TRONIC

34 | Active Body Control suspension

35 | DYNAMIC SELECT drive programs

36 | Mercedes-Benz Intelligent Drive

37 | Driving Assistance package Plus

38 | LED Intelligent Light System

39 | Integral safety concept

40 | Open-air comfort

42 | Spaciousness

43 | Seating comfort

44 | Interior

46 | Infotainment and multimedia

48 | Equipment packages and accessories

54 | Wheels

56 | Mercedes-AMG models

76 | Technical data, dimensions, upholstery, trim and paintwork

The illustrations may show accessories and optional extras which are not part of standard specification.



The looks of a special star.

The unique, striking face conjures up the fondest memories among roadster enthusiasts. The upright radiator grille in its contemporary interpretation of the “Panamericana design” – elegantly reminiscent of the “sports car of the century”. A refined design as a diamond radiator grille in chrome, flanked by the restyled LED High Performance headlamps.







Perfect body language.

The Mercedes amongst roadsters impresses with effortless superiority which seeks to prove nothing. The timeless silhouette, elegance in what is probably its purest yet sportiest form. Extremely progressive, when the SL with the AMG Line available on request draws up.



Its open secret.

The SL does not hide its qualities. With all the roof variants the opening and closing procedure started when moving off can be completed up to a speed of 40 km/h. The SL thus transforms the horizon into an endless sky. Everyday life has long since disappeared from view. The new fully power-adjustable boot separator even takes care of your luggage. Open-air driving pleasure, even outside the cabriolet season – thanks to them AIRSCARF neck-level heating available on request and the electric draught-stop.

Dilates your horizons and your pupils.

Energy in its most thrilling guise. The newly designed wide tail end with integrated tailpipe trims and diffuser in the rear apron – pure dynamism. Showcased to best advantage by large AMG multi-spoke light-alloy wheels.









Sporty refinement in an exclusive vein: the cockpit of the SL possesses a compelling, unique spatial feel, great seating comfort plus lavish use of the most select elements. Choose from a host of materials and colours and the exclusive design programme ranging from elegant Exclusive nappa leather to finely crafted trim in aluminium, wood or carbon fibre.

It's reinventing itself. Just like the first time.

Interpreting traditions in a thrilling new guise. Driving innovation forever onwards. The SL was and is the expression of a strong drive: passion. For a unique driving experience and maximum safety and comfort standards. Manifested in our grand idea of autonomous and accident-free driving: Mercedes-Benz Intelligent Drive.







A legend shows its true face.

What a view – accentuated as standard with the expressive AMG bodystyling. The two powerdomes on the bonnet attest to the power that lurks beneath. The V6 biturbo engine is even more powerful, needing less than five seconds to reach the 100 km/h mark. The measure of all things: the V8 with 335 kW (455 hp) and a maximum torque of 700 Nm – and an unmistakably rich sound.

Beneath it roads turn into legends.

Celebrate every bend, savour the rising, wavy coastal roads and every metre of smooth asphalt in town. The optional Active Body Control suspension ABC offers thrilling agility, curve dynamics or relaxed cruising, depending on your choice. The five DYNAMIC SELECT drive programs offer an even more individual experience. From comfortable to extremely sporty, your memories of a drive in the SL are entirely up to you.









Zooms by like a dream.

Change down, change up a gear, short sharp burst of speed. Take a breather – only you have time to do that. The automatic transmission 9G-TRONIC leaves no second unused. It transmits the SL's output quickly, precisely and without any interruptions to power. And so smoothly that you hardly notice it.



You have read about dynamism and power and about the effortless superiority with which the SL conjures up pure driving pleasure. Here you can see the ergonomics of the performance which ensures that you experience everything more intensely: sports seats with high seat side bolsters and the new multifunction sports steering wheel, providing a good grip, with shift paddles. Your fingers dictate the power, your passion the route.



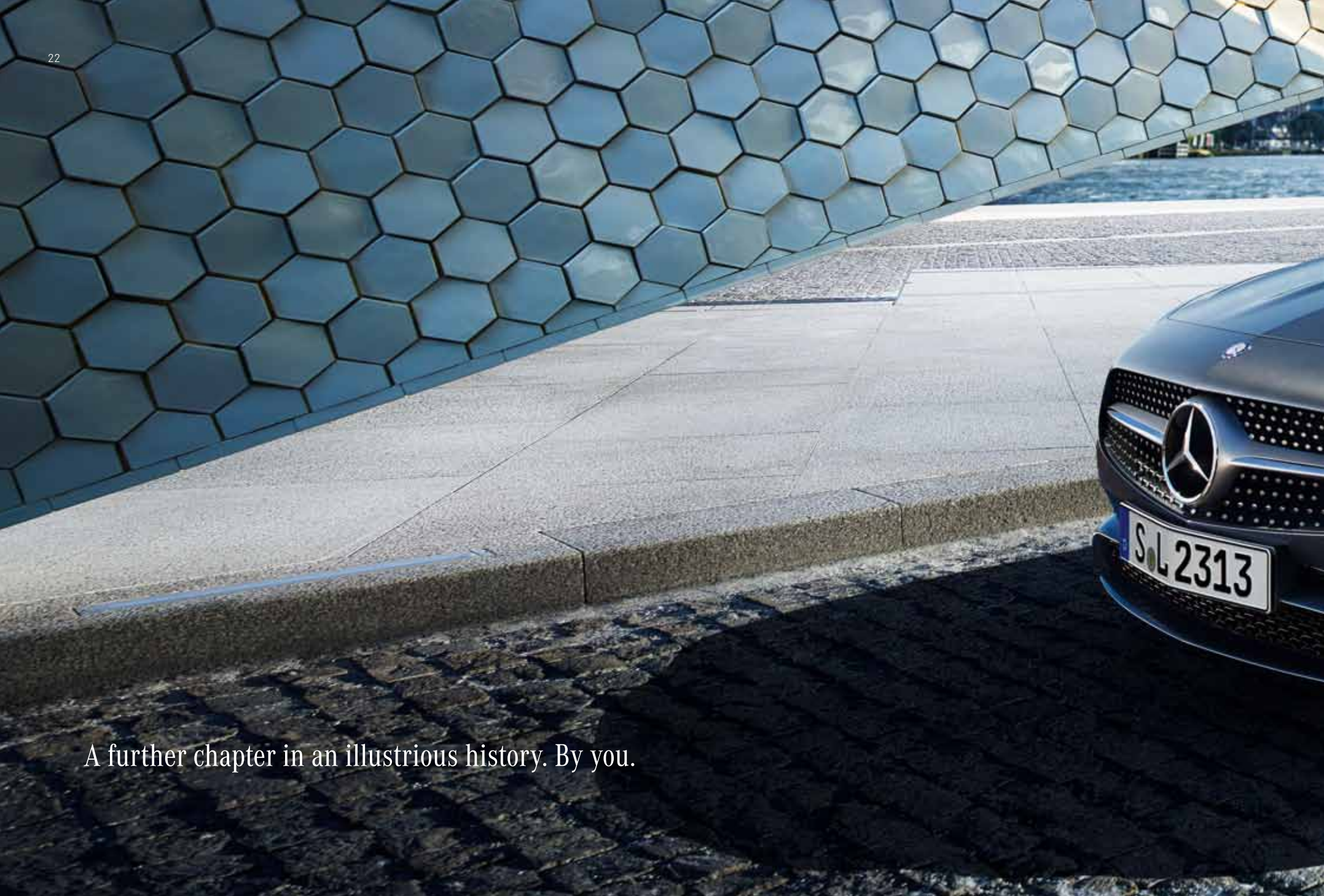

A further chapter in an illustrious history. By you.





Our next great innovation revolves around you.

Prepare to be inspired, surprised and thrilled by new services, products and experiences at www.mercedes.me. You are also warmly invited to check out our Mercedes me stores in major cities such as Hamburg, Milan, Tokyo or Hong Kong.





Mercedes me. Welcome to your Mercedes-Benz world.

You have new questions, Mercedes-Benz has a new answer for you: Mercedes me. Your point of access to a fascinating world of personalised services from Mercedes-Benz. Offering innovative, individualised mobility, connectivity, finance and other services, as well as special brand experiences. All subject to continual development. Innovative, simple and cutting-edge: www.mercedes.me

Join us – on your smartphone, tablet or PC. And let's shape tomorrow's world together. Any time, anywhere.

Mercedes me connect is all about networking the vehicle with the driver – and more besides: the car is becoming part of the way we live, providing added comfort as well as the reassurance of being permanently connected, even while on the move. Mercedes me connect includes Standard Services, which are able to provide you with automatic support in the event of a breakdown or an accident, and Remote Online Services – the option enabling vehicle settings to be carried out by smartphone.



Mercedes me finance offers you various routes to your vehicle of choice. Mercedes-Benz Financial Services finds the ideal leasing, financing and insurance solution together with you – tailored to your needs. Our leasing products enable you to drive the latest models at all times while enjoying maximum flexibility, as you pay not for acquisition of the vehicle, but only for its use. You also benefit from attractive monthly instalments. Our financing arrangements enable you to pay for your new Mercedes-Benz in a way that suits your personal budget. You can tailor your monthly instalments to your needs by deciding on an appropriate down-payment and term for your contract. Our individual insurance solutions offer reliable protection for your budget and your vehicle on attractive terms.

Mercedes me inspire offers special brand experiences and an opportunity to engage in an inspiring dialogue. We aim to share our ideas with you and we would like to know your ideas and wishes. So that we can always offer you the best solutions. A community is available to this end, and you will also find a growing range of offerings and experiences which go beyond the traditional vehicle-related topics – from areas such as events, travel and lifestyle.

Mercedes me move offers access to the intelligent mobility solution moovel: this mobility app pools the offerings from various mobility providers to find the ideal route from A to B. car2go is the pioneer and market leader worldwide in free-floating car sharing, and car2go black stands for smartphone-based car sharing with Mercedes-Benz B-Class vehicles. With the mytaxi app you can order a taxi, track its approach live and pay for your journey in a convenient manner.

Mercedes me assist makes easy work of organising maintenance for your vehicle, providing a convenient online means of locating a Mercedes-Benz dealer in your neighbourhood and arranging a service appointment. The digital service report keeps you up to date on performed service work at all times. The report is available to you online just one day after a service. In addition to the current service report, you can also view your vehicle's complete service history and service intervals, and you can print this information out if you so wish.

**Mercedes-Benz
Service**



Our service: the perfect fit for your Mercedes.

Beyond the car itself, you also acquire something priceless – an exclusive partnership with Mercedes-Benz. For you, this means safety, independence and motoring free of any worries. In other words: the reassuring feeling of driving a Mercedes.

The best for your Mercedes. No-one knows your Mercedes better than our experienced specialists at the Mercedes-Benz workshops. The comprehensive range of services and the high standard of quality ensure that your vehicle is in top condition. We use tested Mercedes-Benz GenuineParts and special tools to this end.

The best for you. Motoring free of any worries right from the word go: with the tailor-made Mercedes-Benz Service Contracts. These offer you the benefits of a reliable basis for long-term planning, permanent control over costs, fixed monthly rates and cost transparency. Plus ideal protection from additional workshop costs.

The best for your mobility. The Mercedes-Benz Mobilo¹ insurance package provides for motoring free of any worries throughout Europe – covering breakdowns, accidents, minor mishaps and vandalism. The benefits offered by Mobilo include on-the-spot assistance, a replacement vehicle, towing and overnight hotel accommodation, for example. This mobility guarantee is automatically on board for the first two years after initial registration, and can subsequently be renewed for a period of up to 30 years in all. Whenever you need assistance, you can reach us free of charge throughout Europe on 00800 1 777 7777².

↘ **FIND OUT MORE**

For the full information on Mercedes-Benz Service Contracts, go to www.mercedes-benz.com/servicevertraege – or ask your authorised Mercedes-Benz dealer to draw up an individual offer for you.

¹ Our general terms and conditions apply. The period of validity is extended after each service carried out by an authorised Mercedes-Benz service partner until the due date for the next service – up to a maximum of 30 years after initial registration. ² Roaming charges may apply when calling from abroad.

What would motorsport be without Mercedes-Benz?

The first vehicle to ever win an automobile race was powered by a Daimler engine. The first Mercedes was a racing car. The Silver Arrows – a true legend. Mercedes-Benz has a long tradition of involvement with the world of sport. Motorsport shapes the brand and every vehicle bearing the Mercedes star to this day. Discover the brand's unique history first-hand: at the Mercedes-Benz Museum in Stuttgart.

↘ FIND OUT MORE

Discover just what has been moving the world for almost 130 years and take a journey through time as well as through the history of the automobile at the Mercedes-Benz Museum. More than 1500 exhibits await you on 16,500 sqm of floor-space, including unique gems such as the oldest surviving Mercedes from 1902 or the legendary gull-wing models. Welcome to a place of innovation:

www.mercedes-benz.com/museum



What would Mercedes-Benz be without motorsport?

3 June 1934 marked the beginning of the Silver Arrows legend in the International Eifel Race at the Nürburgring. The Silver Arrows works team MERCEDES AMG PETRONAS continued this tradition in the 2014 Formula 1 season. Its successful involvement was crowned by the most impressive double victory of the season, with the team topping both the constructors' and the drivers' rankings. The team's successes are not restricted to the race track, however. Every mile raced also advances the development of hybrid technology for series production.

FIND OUT MORE

Fascinating Formula 1 goes multimedia:

<http://www.facebook.com/MercedesAMGF1>

<http://twitter.com/MERCEDESAMGF1>

<http://www.youtube.com/user/MERCEDESAMGPETRONAS>

<http://plus.google.com/+Mercedesamgf1/posts>

<http://instagram.com/MercedesAMGF1#>

<http://www.MercedesAMGF1.com>



MERCEDES AMG PETRONAS F1 W06 hybrid, 2015 season.



Performance for storms of enthusiasm.

The SL's new-generation engines impress with their pulling power and refinement, unleashing intense feelings. The 6-cylinder petrol engine of the **SL 400** generates an output of 270 kW (367 hp) and produces a maximum torque of 500 Nm – for powerful acceleration even at low engine speeds. The consistent lightweight construction, turbocharging, spray-guided direct injection with precise piezo injectors plus adjustable intake and outlet camshafts ensure less consumption and more output. The **SL 500** makes 335 kW (455 hp) and 700 Nm maximum torque available. The biturbocharging with inter-cooling offers huge reserves of torque. Effortless superiority at all times.

As standard both units include the **ECO start/stop function**, which can save fuel at traffic lights or in slow-moving traffic and thus relieve the burden on the environment – without any compromises where refinement and dynamism are concerned.

SL 400 V6

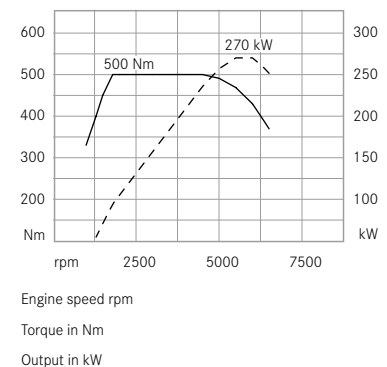



The control centre for the highest of emotions. 9G-TRONIC.

The SL lives from the ease of bringing power playfully to the road. This is achieved in an especially elegant way with the **automatic transmission 9G-TRONIC**. With nine forward gears, the 9G-TRONIC enables efficiency, comfort and dynamism of an entirely new dimension. It is the world's first nine-speed automatic transmission with a hydrodynamic torque converter in the premium segment. The wider gear spread allows a reduction in engine speed. The excellent driving performance thus remains unchanged while ride comfort is enhanced and noise levels are reduced. Smaller gear ratio increments and faster gear changes lead to even greater responsiveness and agility. At the same time, the 9G-TRONIC impresses with its smooth, barely perceptible gear shifting. As 9G-TRONIC is able to skip individual gears, multiple downshifts are possible for fast and powerful sprints.

DRIVE SYSTEMS

The car's transmission setting can be moved between R, N and D using the ergonomic **DIRECT SELECT lever** in the centre console. Parking mode is set using the P button, which is located in front of the selector lever in the centre console.

Cruise control with variable speed limiter allows relaxed and fuel-saving driving especially on long journeys. In addition to the desired cruising speed, an individual maximum speed can be set, for example to be sure of obeying speed limits.



The ABC of supreme suspension technology. With a leaning towards even greater agility.

Enhanced ride comfort combined with optimised driving dynamics – the optional Active Body Control suspension ABC performs this balancing act with the aid of four hydraulic active suspension struts. This configuration results in reduced pitching when moving off and braking and diminished rolling during cornering. Or, to put it another way: the SL hugs the road for all it's worth. And the effective damping ensures a high level of ride comfort, even when set to a sporty mode.

At high speeds, the car is lowered automatically in order to increase driving stability. The “Curve” setting offers a unique driving experience. Similar to the carving technique in skiing, it reverses the natural rolling motions, allowing the SL to lean elegantly into bends. On country roads and motorways the active curve tilting technology offers a unique feeling behind the wheel and added comfort. Plus, of course, loads of driving pleasure.



DYNAMIC SELECT. The name speaks for itself.

At a touch of the DYNAMIC SELECT feature in the centre console, drivers can choose between comfortable, sporty, particularly sporty and efficient driving styles, or their own individually defined style. To achieve this, parameters such as the engine, transmission, suspension and steering characteristics are adjusted according to the selected transmission mode. The default setting is the well-balanced and fuel-efficient “Comfort” mode. Greater agility and dynamism is offered by the “Sport” transmission mode with more progressive steering characteristics, sporty, firm suspension tuning, spontaneous throttle response and

modified shift points. The element of sportiness can be enhanced even further in the “Sport Plus” mode. In this case, the suspension and drive system are even more dynamically tuned. The ECO start/stop function is deactivated. The “Eco” transmission mode is designed to keep fuel consumption as low as possible. This includes adjustments to the accelerator pedal curve and shift points. In addition, the output of equipment items such as seat heating, the heated rear window and the air conditioning is similarly adjusted. The “Individual” mode facilitates an even more personal adjustment of the various parameters.

SUSPENSION AND STEERING

Added comfort and more fun at the wheel come courtesy of the electronically controlled **chassis with its adaptive damping system**. In order to adjust the damping forces at each wheel as well as possible to the current vehicle speed and state of the road, the system constantly adjusts its characteristics in an infinitely variable manner.

The **Direct-Steer system** supplements the comfort of speed-sensitive power steering with a variable steering ratio dependent on the steering angle. On winding roads, for example, this produces a more agile handling response and improved straight-line stability. It also reduces steering movements and effort when parking and manoeuvring.

Off to new horizons. Mercedes-Benz Intelligent Drive.

We are driven by the vision of autonomous and accident-free driving. We call it: **Mercedes-Benz Intelligent Drive**. What does this mean in concrete terms? In conjunction with the Driving Assistance package Plus the SL takes in its surroundings more intensely, precisely and quickly thanks to the stereo multi-purpose camera and radar sensors. Intelligent algorithms and powerful processors evaluate the information and can use it to detect and classify oncoming or crossing vehicles or vehicles in front, as well as pedestrians and even different types of traffic signs and road markings.

↘ FIND OUT MORE

Discover the fascinating world of **Mercedes-Benz Intelligent Drive** for computers, tablets or smartphones at www.mercedes-benz-intelligent-drive.com

MERCEDES-BENZ INTELLIGENT DRIVE

A stereo camera, short- and long-range radars and all-round sensor systems form the basis for numerous safety and assistance systems in the new SL.

- 1 | Stereo multi-purpose camera.
- 2 | Long-range radar with intermediate range sensing.
- 3 | Short-range radar.
- 4 | Ultrasonic sensors.
- 5 | Multi-mode radar.

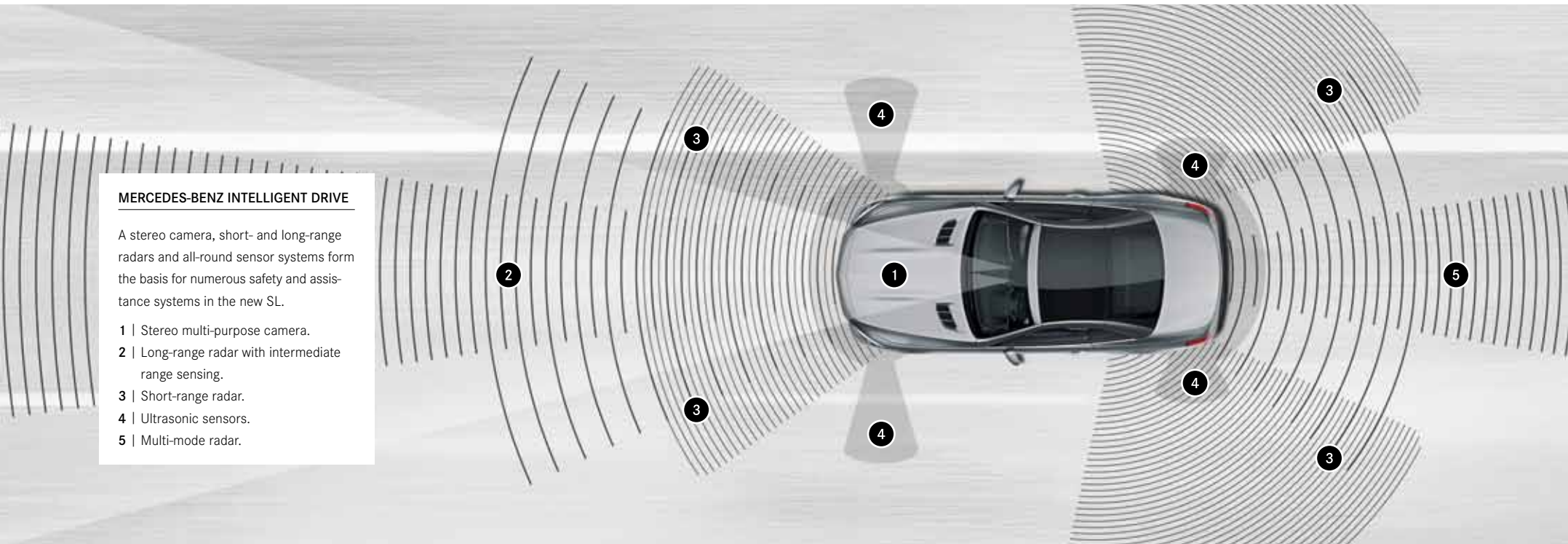

Driving Assistance package PLUS minus dangers.

Intervening where necessary. Holding back where possible. This effortless superiority is part of the optional Driving Assistance package Plus. It combines safety and assistance systems which help to relieve driver strain, reduce the risk of accidents and improve protection for both the occupants and other road users: the Distance Pilot with **Steering Pilot** helps the driver to maintain a safe distance from vehicles travelling ahead and to keep the car in the centre of the lane. The **Active Brake Assist with cross-traffic function** can reduce the risk of rear-end collisions and accidents at intersections as well as collisions with pedestrians.

The **Active Lane Keeping Assist** offers support if the car leaves its lane unintentionally. The driver receives a haptic warning via pulsed steering-wheel vibrations. If there is no reaction from the driver, in the second stage the car can be led back into the lane through one-sided brake actuations. **PRE-SAFE® PLUS** expands the **PRE-SAFE®** preventive occupant protection system to include protective measures in the event of an imminent rear impact.





When even the light outshines itself.

The restyled dynamic **LED High Performance headlamps** radiate good looks and intelligence. With an exceptional day and night design and with something you can expect from a Mercedes-Benz: sophisticated and efficient technology. The LED Intelligent Light System boasts very low energy consumption and a long service life. But above all, it offers even greater visibility and safety. When turning off, the cornering light function enhances safety at junctions by illuminating the road to the sides more effectively. The active light function boosts safety in bends. And for the best possible visibility on rural roads and motorways, the low-beam lights adapt automatically to the light and driving conditions.

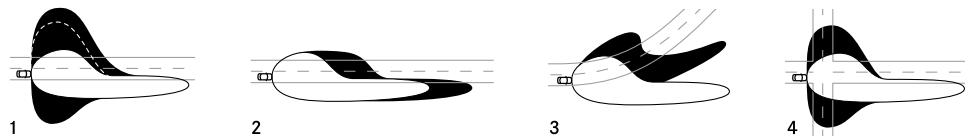

LED INTELLIGENT LIGHT SYSTEM

The **LED Intelligent Light System** in concrete terms: **1** | On rural roads the left-hand side of the carriageway is significantly better illuminated, in particular also when the fog lights are switched on. **2** | On motorways vision is extended by up to 60 percent. **3** | The active light function boosts safety in bends. **4** | The cornering light gives better illumination of the road surface through additional light on the inside of the corner. The extended fog lamp function reduces dazzling of the car's driver due to light reflected by the fog.

MORE LIGHT

The **Adaptive Highbeam Assist Plus** facilitates driving with main-beam headlamps on permanently, without dazzling other road users. This means that the best possible headlamp range is always available to the driver. The function is active from a speed of 30 km/h on unlit roads.

In addition the **tail lights featuring LED technology** add striking visual highlights and improve safety through their rapid response.

The reassuring feeling of driving a Mercedes-Benz.

We are the first automotive manufacturer worldwide to have developed an **integral safety concept**, aimed at avoiding accidents, ensuring ideal responses to dangers and lessening the consequences of accidents. For the occupants of a Mercedes and for all other road users, too.

SAFE DRIVING

In particular on long trips and when driving at night **ATTENTION ASSIST** can increase handling safety. It can monitor the steering behaviour of the driver to detect typical signs of drowsiness and severe loss of attention, plus give a visual and audible warning of impending microsleep.

The enhanced **Traffic Sign Assist** – only available in conjunction with the optional COMAND Online – including the wrong-way warning function can detect limit speeds, no access and no overtaking signs plus their revocation and display them for the driver. If the vehicle enters a road against the posted allowed direction of travel, a visual and audible warning is issued.

The **Active Blind Spot Assist** can warn the driver of vehicles in the blind spot during a lane change, and help to avoid a collision by initiating a one-sided brake actuation. It is part of the optional Driving Assistance package Plus.

IN THE EVENT OF DANGER

The **occupant protection system PRE-SAFE®** is able to identify critical driving situations in advance and to initiate precautionary measures to protect the vehicle's occupants if an accident appears imminent. Such measures include reversible belt tensioning or automatic closing of open side windows, for example.

The SL boasts the **Active Brake Assist** as part of its standard equipment. The optional **Active Brake Assist with cross-traffic function** is part of the Driving Assistance package Plus and when the risk of accident is detected it can warn, provide support in emergency braking and if necessary brake automatically. It can detect slower-moving, stopping and stationary vehicles as well as cross traffic at junctions and pedestrians in the danger zone with the aid of radar sensors and the stereo camera. If danger is detected, the system gives the driver a visual and audible warning. If the driver reacts and brakes, it can boost the braking effect on demand if required, right up to full brake application. If they do not react, the Active Brake Assist can autonomously brake the car outside of cross-traffic situations.

IN AN ACCIDENT

A comprehensive protective system can reduce the risk of injury for occupants and other road users. It includes the **active bonnet**, which can automatically rise up a few centimetres in the event of a severe impact and thus helps to protect pedestrians or cyclists. Numerous **airbags** can protect the occupants in the event of an accident and can reduce the risk of serious injury.

AFTER AN ACCIDENT

Every Mercedes-Benz is optimally trained in first aid. If the worst comes to the worst, the engine can be switched off automatically, the hazard warning lights plus the emergency interior lighting can be activated, and the central locking can be unlocked. Finally the **Mercedes-Benz emergency call system** integrated as standard (country-specific) can send GPS position data and important vehicle information, though it is to be hoped this will never be necessary.

A cabriolet through and through. With a touch of practical finesse.

Even when the sun fails to shine, an open-air drive is always a pleasure in the SL. The neck-level heating system **AIRSCARF** (standard in the Mercedes-AMG SL 65) ensures comfortable open-top motoring even in low temperatures. Through adjustable air outlets in the head restraints, pleasantly warm air is “wrapped” around the necks of the driver and passenger like an invisible scarf. The desired temperature can be adjusted in three levels. The air to be warmed up flows over fins and is heated up by a heating element. A blower then ensures the required outflow speed. The outflow speed is automatically adjusted to the travelling speed. The optional **electric draught-stop** offers protection against draughts at the press of a button. This can be extended or retracted by either the driver or the passenger, even while on the move, by simply pressing a button. When retracted, it disappears completely into the rear compartment trim cover. Pressing the draught-stop button below the handrest in the centre console triggers an electric motor into unfolding a trapezoidal frame around a fine-mesh net, designed to protect passengers from any draughts.

With the **automatic boot separator** the SL proves that even legends reinvent themselves over and over again. Up until now the separator between the boot and the vario-roof could only be moved into an opened or closed position by hand. Now this procedure is carried out automatically. If the separator is in the upper position (for increased boot capacity), it automatically moves down when the top is opened. On the other hand, the automatic boot separator returns to the upper position when the flap is opened. The system operates extremely safely: if there are any obstacles or if there is insufficient space due to luggage, the separation procedure is automatically interrupted. In this case the driver receives a notification via the instrument cluster: “Close boot separator”. A useful feature: the automatic opening of the boot separator in the loading aid position makes it possible to load the boot without having to put the luggage down.



**VARIO-ROOF**

The SL combines the unparalleled driving pleasure of a roadster with the suitability for everyday use and quiet-running characteristics of a coupé. It takes just the press of a button to open and close the folding vario-roof in less than 20 seconds. The procedure started when moving off can be completed up to a speed of 40 km/h.



Always closest to the sky.

That al fresco feeling even with the roof closed comes courtesy of **MAGIC SKY CONTROL** on request, and at the touch of a button. The electrochromatic glass of the panoramic vario-roof changes from opaque to transparent and vice versa in a matter of seconds. In its tinted state, it substantially reduces heating-up of the vehicle interior. **MAGIC SKY CONTROL** is activated via a switch in the overhead control panel. When electrical voltage is applied, particles in the glass structure align themselves so that light can pass through the glass. The passengers enjoy a clear view of the sky and a particularly light and friendly atmosphere in the interior. The glass darkens when the voltage is switched off. The particles are distributed randomly and stop most of the light from passing through.

SPACIOUSNESS

The optional **panoramic vario-roof** including a roller blind (standard for Mercedes-AMG SL 65) combines the spectacular view afforded by a roadster with the quiet-running characteristics of a coupé. A clear overhead view is ensured by a large glass section in the roof panel. The roller blind over this is manually operated and provides protection from intrusive glare from the sun.

In the best seats.

On request the driver and passenger can enjoy particularly exclusive comfort – with the **Active Multicontour Seat package**. Thanks to their inflatable air chambers, the active multicontour seats with massage function and dynamic function ensure optimum seating comfort and excellent lateral support. The seats can be individually adjusted via various air chambers – from the seat cushion length through the side bolsters to the position and extent of the backrest curvature. An adjustable lumbar support gives added support to the spine. When on the move, the side bolsters of the backrests automatically and dynamically adapt to vehicle movements to provide even better lateral support on winding roads and when adopting a sporty driving style. The massage function with four selectable levels offers relaxed travel in particular on longer journeys.

SEATING COMFORT

On cold days, the **seat heating for driver and passenger** (optional in the SL 400) very rapidly ensures cosy warmth as desired. Three different heating levels can be selected at each seat at the touch of a button.

Thanks to active ventilation, on hot days the optional **climatised seats** quickly cool down the surface of the seats to a pleasant temperature and create a balanced seat climate. In cold weather the engageable seat heating provides pleasant seat temperatures.

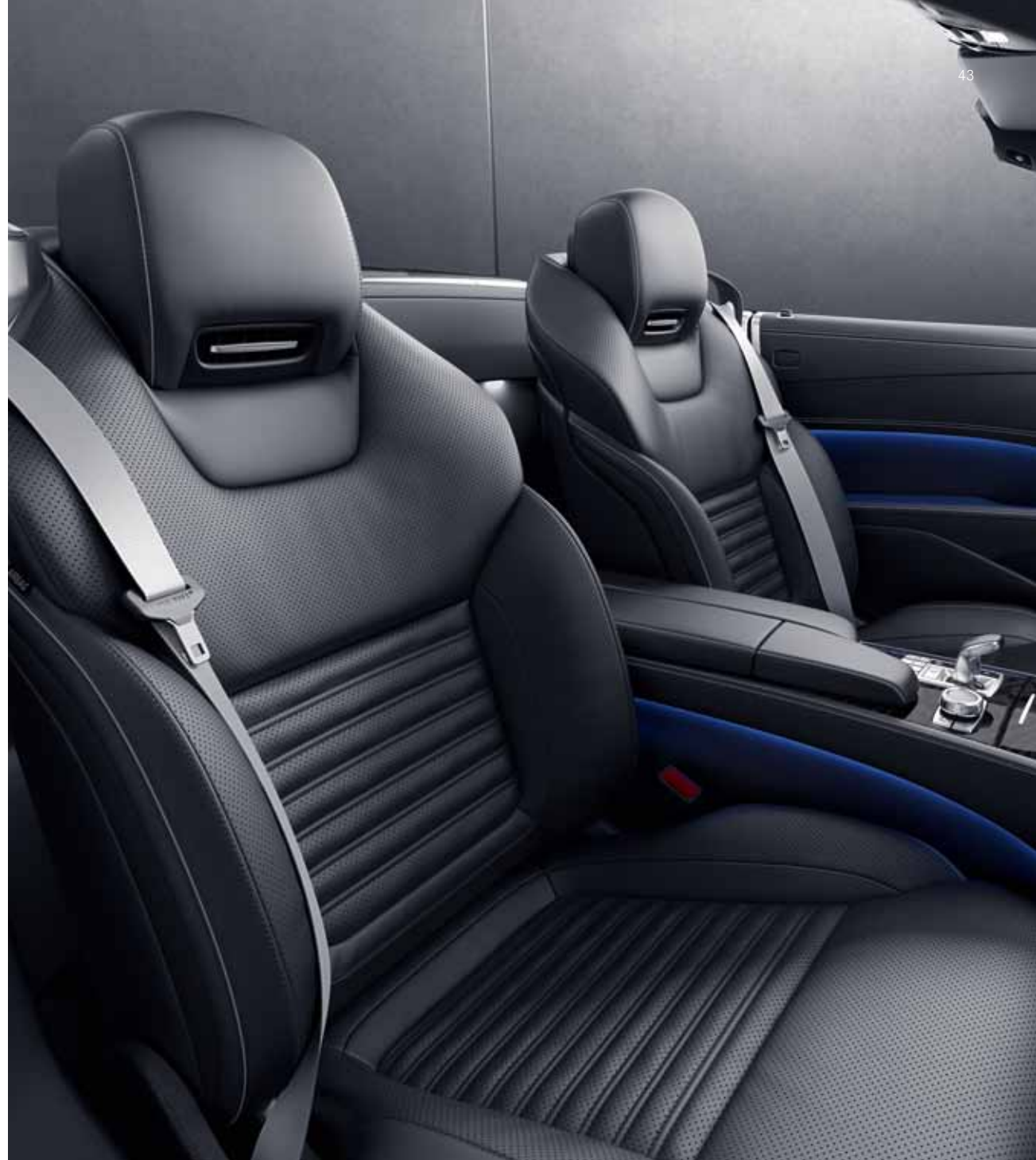



Reflects good taste and the sun.

The interior is precisely adapted to the ergonomics of the driver and passenger. But anyone who drives an SL is also met by a decidedly aesthetic ambience. In the SL 500 this means ex-factory upholstery in leather in various colours and trim in aluminium or fine woods. On request, choice leather variants featuring a longitudinal or cross-piping design, combined with selected trim, meet the most discerning standards. Like the crystal grey/black leather upholstery with trim in high-gloss black ash wood, saddle brown/black Exclusive nappa leather with light carbon-grain aluminium trim or light brown satin-finish poplar wood. They attract glances and reflect the light of the sun – for high seating comfort.

INTERIOR HIGHLIGHTS

Leather upholstery in four colours for SL 500 (standard)

Multifunction sports steering wheel in nappa leather, flattened bottom section, and airbag cover in nappa leather (standard)

Light carbon-grain aluminium trim, optionally available for no extra charge, from V8 model upwards trim in wood also optionally available for no extra charge

DIRECT SELECT lever and **DIRECT SELECT steering wheel gearshift paddles** for the 9G-TRONIC plus **DYNAMIC SELECT** comprising five drive programs (standard)

Automatic boot separator (standard)





A fascinating composition.

SL and Bang & Olufsen®, a fine liaison. The optional **Bang & Olufsen BeoSound AMG** high-end surround sound system – standard for the Mercedes-AMG SL 65 – was specially developed for the SL. Twelve high-performance loudspeakers, ICEpower amplifiers with DSP and a total output of 1020 watts produce tailor-made acoustics. Innovative solutions facilitate clear and precise sound reproduction. Via the digital sound processor, DSP, various sound settings can be made, and the tweeters' acoustic lens technology ensures the characteristic virtual sound stage in front of the occupants. The aesthetic design of the illuminated tweeters and high-quality loudspeaker grille in aluminium completes the experience.

INFOTAINMENT HIGHLIGHTS

Carefully coordinated technical components of the optional **Harman Kardon® Logic 7® surround sound system** with a total output of 600 watts and 11 high-performance loudspeakers ensure an unmistakably authentic soundscape. Passengers in all seats enjoy an enthralling 360° sound experience for both stereo and 5.1 multi-channel recordings.

Loudspeakers with Frontbass – in the SL all three available sound systems have Frontbass technology. The standard-fit sound system with a total of eight loudspeakers provides a brilliant and balanced sound even during open-top motoring. The woofers are integrated into the bodyshell, and use the space within the side members as resonance chambers for first-class bass reproduction.

Out and about in a networked world.

Navigation, telephone, audio, video, internet – with the control and display system **COMAND Online** (optional for the SL 400) the driver keeps these and many other functions in sight and under control. Information is shown in colour on a 17.8 cm (7-inch) high-resolution media display. Operation is simple and intuitive. Fast hard-disc navigation with realistic topographical map display for relaxed route guidance. In combination with a suitable mobile phone it is possible to call up internet pages when the vehicle is stationary, and to use Mercedes-Benz Apps such as POI search, weather or internet radio while driving.

FURTHER HIGHLIGHTS

The use of **Live Traffic Information** (part of COMAND Online) facilitates the reception of the latest and precise traffic information for optimised dynamic route guidance and more precisely calculated arrival times. Data transfer is with a communication module via a fast mobile internet connection.

Convenience Telephony – a universal interface in the armrest lets you connect mobile phones conveniently to the HD-voice-capable vehicle's hands-free system. To do this the mobile phone is simply placed in a cradle (accessory) suitable for the phone model.

On request the **ambient lighting** with the colours solar red, polar blue and polar white for the centre console, armrests and footwell create a special lighting mood.





The AMG Line. The sports outfit.

In an SL you're headed for the sun in dynamic style ex factory – courtesy of AMG bodystyling. The AMG Line presents the SL in a yet sportier guise.

AMG EXTERIOR BODYSTYLING HIGHLIGHTS (STANDARD)

AMG-specific front apron in A-wing design

Diamond radiator grille in matt iridium silver and insert in high-gloss chrome

AMG-specific rear apron with diffuser look in vehicle colour and side air outlets

AMG-specific side sill panels

AMG EXTERIOR LINE HIGHLIGHTS

48.3 cm (19-inch) AMG 5-spoke light-alloy wheels, painted titanium grey with a high-shine finish

Perforated brake discs at the front and rear, brake callipers on the front and badges on the rear painted grey and with “Mercedes-Benz” lettering

Sports suspension with tauter springing and damping configuration plus lowered by 10 mm

Sporty engine sound, selectable via drive programs for the V6 engine

PURE AMG

Experience all the fascination of AMG from page 56.



Performance-oriented, this is how the SL with the AMG Line interior presents itself. Thanks to sporty seats in various leather versions with a specific vertical piping design and the 3-spoke multifunction steering wheel, which provides a good grip and has a flattened bottom section, in nappa leather.

AMG INTERIOR LINE HIGHLIGHTS

3-spoke multifunction sports steering wheel in nappa leather with grey contrasting topstitching

Seats with specific vertical piping with upholstery in leather, nappa leather or Exclusive nappa leather, in black and perforated in each case as well as designo platinum white pearl edging in the door armrests, centre console, the seat side bolsters and the head restraints

Light or dark longitudinal-grain aluminium trim

Instrument cluster in “Chequered Flag” design

Roof liner in black

Roof liner in black DINAMICA (only in conjunction with Exclusive nappa leather, not in conjunction with upholstery colour ginger beige/espresso brown)

AMG velour floor mats with “AMG” lettering



The AMG Night package. Stylish in black.

On the basis of AMG Line, optional extras with distinctive design features in high-gloss black lend the SL an even more uncompromising and more expressive character.

EXTERIOR HIGHLIGHTS

48.3 cm (19-inch) AMG multi-spoke light-alloy wheels, painted high-gloss black with a high-sheen finish (optional)

Front splitter in high-gloss black

Exterior mirror housings in high-gloss black

Diffuser insert on the rear apron in high-gloss black



The fascination of designo.

Your demands concerning exclusivity are met in the designo range on request. The fine selection of upholsteries, such as designo Exclusive leather, or carefully crafted trim in black piano lacquer perfect the SL's sporty ambience.

designo HIGHLIGHTS

designo paintwork available in three colours

Eight designo interior colours for selection, for example designo Exclusive leather in platinum white/black with a roof liner in black leather

designo roof liner available in a total of six different colour and material variants

Trim in designo champagne white piano lacquer, black piano lacquer or designo natural bamboo

designo seat belts in red or silver

designo leather steering wheel, two-tone

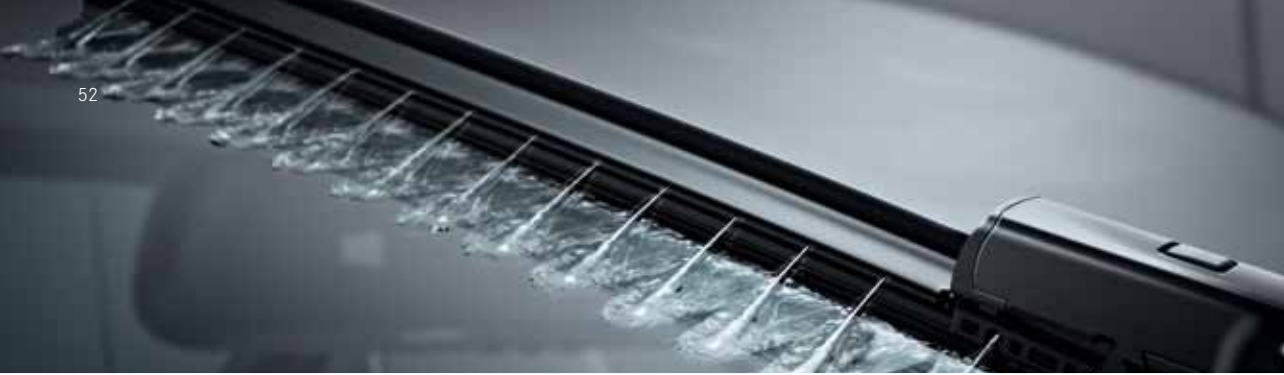

Optional extras.

From fine details to a unique atmosphere and refined technical solutions – the possibilities are virtually limitless. Take a look round, here in the brochure, in the price list or at www.mercedes-benz.com. Style your SL completely in accordance with your wishes.

HIGHLIGHTS AT A GLANCE

The **heated adaptive windscreen wiper system MAGIC VISION CONTROL** provides the driver with an optimum view even while wiping. The washer fluid is sprayed directly in front of the wiper blades and wiped away without delay. The heating system effectively lowers the risk of icing-up.

Multifunction steering wheel in wood/leather design.

The **KEYLESS-GO Convenience package**, including remote boot lid closing, enables the car to be conveniently opened, started and locked – all you have to do is carry the electronic key. The **HANDS-FREE ACCESS** function allows contactless, fully automatic opening and closing of the boot.

Reverse parking and manoeuvring is made much easier and safer by the **reversing camera**. It is switched on automatically when the driver selects reverse gear, and shows the driver the area behind the vehicle with dynamic guide lines on the media display.

Genuine accessories.

How is it possible to refine an icon? With the extensive range of genuine accessories. Every accessory is specially developed for the SL in accordance with the high Mercedes-Benz quality standards. Discover the entire range at www.mercedes-benz-accessories.com

HIGHLIGHTS AT A GLANCE

5-spoke light-alloy wheels with 225/35 R 19 tyres, at the rear optionally with 285/30 R 19 tyres, painted black with a high-sheen finish.

5-spoke light-alloy wheels with 225/40 R 18 tyres, at the rear optionally with 285/35 R 18 tyres, matt satin silver and high-sheen.

Shallow **boot tub** made from impact-resistant polypropylene with an anti-slip effect. Suitable for transporting foodstuffs.



54



40R



R82



11R 785



R70



R97



752 662



Wheels.

Beneath the SL roads turn into legends. For an appropriate outfit we have compiled a large selection of wheel rims for you. From stylishly elegant to extremely sporty – so that you make the best impression on every road.

STANDARD EQUIPMENT AND OPTIONAL EXTRAS

40R Multi-spoke light-alloy wheels, painted vanadium silver, with 255/40 R 18 tyres (standard for SL 400)

R70 5-twin-spoke light-alloy wheels, painted vanadium silver, with 255/40 R 18 front and 285/35 R 18 rear tyres (standard for SL 500; option for SL 400)

R82 5-spoke light-alloy wheels, painted high-gloss black with a high-sheen finish, with 255/35 R 19 front and 285/30 R 19 rear tyres (option for SL 400 and SL 500)

R97 10-spoke light-alloy wheels, painted high-gloss black with a high-sheen finish, with 255/35 R 19 front and 285/30 R 19 rear tyres (option for SL 400 and SL 500)

11R Multi-spoke light-alloy wheels, painted vanadium silver with a high-sheen finish, with 255/35 R 19 front and 285/30 R 19 rear tyres (accessory wheel ex factory for SL 400 and SL 500)

752 AMG 5-spoke light-alloy wheels, painted titanium grey with a high-sheen finish, with 255/35 R 19 front and 285/30 R 19 rear tyres (option for SL 400 and SL 500; component of AMG Line)

785 AMG 7-twin-spoke light-alloy wheels, painted titanium grey with a high-sheen finish, with 255/35 R 19 front and 285/30 R 19 rear tyres (option for SL 400 and SL 500)

662 AMG 7-twin-spoke light-alloy wheels, painted titanium grey with a high-sheen finish, with 255/35 R 19 front and 285/30 R 19 rear tyres (option for SL 400 and SL 500); component of the AMG Night package for SL 400 and SL 500)

788 AMG multi-spoke light-alloy wheels, painted titanium grey with a high-sheen finish, with 255/35 R 19 front and 285/30 R 19 rear tyres (option for SL 400 and SL 500)



788



799



657



606



659



658

606 AMG multi-spoke light-alloy wheels, painted high-gloss black with a high-sheen finish, with 255/35 R 19 front and 285/30 R 19 rear tyres (option for SL 400 and SL 500; option for the AMG Night package for SL 400 and SL 500)

799 AMG 10-spoke light-alloy wheels, painted titanium grey with a high-sheen finish, with 255/35 R 19 front and 285/30 R 19 rear tyres (standard for Mercedes-AMG SL 63)

659 AMG 10-spoke forged wheels, ceramically high-gloss polished, with 255/35 R 19 front and 285/30 R 20 rear tyres (standard for Mercedes-AMG SL 65)

657 AMG cross-spoke forged wheels, painted titanium grey with a polished finish, with 255/35 R 19 front and 285/30 R 20 rear tyres (option without an extra charge for Mercedes-AMG SL 65; option for Mercedes-AMG SL 63)

658 AMG cross-spoke forged wheels, painted matt black with a polished finish and high-sheen rim flange, with 255/35 R 19 front and 285/30 R 20 rear tyres (option without an extra charge for Mercedes-AMG SL 65; option for Mercedes-AMG SL 63)

↘ FURTHER WHEELS

can be found in our accessories range. Information on the range of Mercedes-Benz Genuine Accessories is available at www.mercedes-benz-accessories.com or from your authorised Mercedes-Benz dealer.

High-performers. The Mercedes-AMG SL 63 and the Mercedes-AMG SL 65.

Mercedes-AMG is not just a manufacturer of performance vehicles and sports cars, AMG is a promise. The promise to give everything and always to go one step further. To this end we create extraordinary cars for extraordinary people.

With the Mercedes-AMG SL 63 and the SL 65 we are again underlining our claim to pull out all the stops – in every moment, every metre of the way. Allow yourself to be enthralled by effortlessly superior power delivery, extraordinary driving dynamics and the good looks and elegance of thoroughbred sports cars which, even at standstill, make it abundantly clear what they are made for: Driving Performance.

Welcome to the world of AMG.

DRIVING PERFORMANCE





DYNAMISM





Power and control.

Out in the wild the Mercedes-AMG SL 63 shows what it can do best: unleash storms of enthusiasm. A 256-kilogram-light all-aluminium bodyshell is paired with a powerful 430 kW (585 hp) – ideal prerequisites for first-class performance with impressive efficiency. In 4.1 seconds the AMG 5.5-litre V8 biturbo engine accelerates from 0 to 100 km/h. Optimum power transmission is delivered by the AMG SPEEDSHIFT MCT 7-speed sports transmission with a double-declutching function in conjunction with the AMG sports suspension with Active Body Control. They ensure fast gear changes and through the selection of different drive programs offer an impressive range of sportiness and comfort. Perfectly matched: the rear axle differential lock for yet more traction, in particular when accelerating out of bends. The Mercedes-AMG SL 63 – as precise and to the point as you are.



All manner of things. Just not mannered.

Long bonnet, occupant compartment positioned much further back, large wheelbase – the silhouette of the Mercedes-AMG SL 63 systematically reflects the AMG design idiom. Characteristic features: the sporty side sill panels, AMG high-sheen cross-spoke forged wheels painted matt black and an AMG high-performance compound braking system with perforated and internally ventilated brake discs. Distinctive detail: the silver-chromed “V8 BITURBO” lettering in the centre of the air outlets. The Mercedes-AMG SL 63 makes a statement – sign it.





PERFECTION

Tailor-made suit.

The interior is just as dynamic and elegant as the exterior. Precisely contoured AMG sports seats covered with nappa leather snugly fit the body like a made-to-measure suit and ensure optimum lateral support. The AMG instrument cluster in the cockpit displays all the key information at a glance. The AMG DRIVE UNIT with the AMG DYNAMIC SELECT Controller gives you a choice of five drive programs including the RACE START function. And by the time you grip the AMG performance steering wheel with aluminium shift paddles there can be no doubt: the Mercedes-AMG SL 63 is made for you.

A real character.



The Mercedes-AMG SL 63 is a true phenomenon. Power and determination are written all over its face. This impression is underlined by the bonnet shaped by distinctive powerdomes, the headlamp housings extending far outwards and the radiator's twist with a twin louvre in silver chrome. Another eye-catching feature is the powerful style of the front apron with its A-wing in high-gloss black and large air intakes. Along with the rear apron with its large diffuser and side air outlets the hallmark AMG pert spoiler lip forms the perfect conclusion. One step on the accelerator and the rich AMG 8-cylinder sound rings out from the AMG sports exhaust system with chromed twin tailpipe trims. As unambiguous as you are.



A white Mercedes-AMG SL 65 convertible is driving on a winding road. The car is in the center of the frame, moving towards the right. The background shows a hazy landscape with mountains and a body of water. The foreground is a blurred road surface, suggesting motion. The car's design features, such as the chrome grille and side skirts, are visible. The overall scene is dynamic and emphasizes the car's performance.

Manager.

The Mercedes-AMG SL 65 impresses with its expressive appearance and superb performance. Characteristic: the high-gloss chrome appliqué sections on the radiator grille, the front splitter, the flics on the cooling air intakes, the fins and trim on the side skirts plus the trim strip on the rear apron. Beavering away beneath the long bonnet is an AMG 6.0-litre V12 biturbo engine, which in combination with the AMG SPEEDSHIFT PLUS 7G-TRONIC offers extraordinary performance in conjunction with the comfort of an automatic torque converter and the speed of a sports transmission. The result: extraordinary driving dynamics, thrilling acceleration and refined running with the rich V12 sound so characteristic of AMG.



V12





Power and elegance.

The Mercedes-AMG SL 65 displays the hallmark attributes of a top athlete. Precisely sculpted surfaces, side skirts with inserts in high-gloss chrome, enlarged air outlets in the front wings with “V12 BITURBO” lettering and a striking tail end with a large diffuser, an AMG sports exhaust system and chromed twin tailpipe trims in a AMG V12 design. A car made for people who know what they want.



Form and function.

Every detail of the Mercedes-AMG SL 65 radiates stylish aesthetics and sporty function. Sports seats covered in nappa leather and featuring the AMG-specific diamond design with the embossed AMG emblem, AIRSCARF and climatized seats ensure optimum lateral support. The AMG performance steering wheel with silver-coloured aluminium shift paddles and the AMG instrument cluster with its AMG main menu including RACETIMER and a 360 km/h scale promise maximum sportiness. Music to your ears: the Bang & Olufsen BeoSound AMG high-end surround sound system. Attention-grabber: the ceramically high-gloss-polished AMG 10-spoke forged wheels. So why look any further? You have arrived.

The image shows two Mercedes-AMG engines displayed in a dark, industrial setting. The engine in the foreground is a V8 biturbo engine, likely the 5.5-liter model, mounted on a metal stand. It features a prominent black carbon fiber intake plenum with the Mercedes-Benz logo and 'AMG' branding. The engine block is highly detailed, showing various components like the turbochargers, intake manifold, and cooling fans. The second engine, a V12 biturbo model, is visible in the background, also on a stand. The floor is dark with a yellow and black striped safety line. The overall lighting is dramatic, highlighting the metallic and carbon fiber textures of the engines.

Engines.

At work in the Mercedes-AMG SL 63 is an AMG V8 biturbo engine manufactured according to the AMG philosophy “One Man – One Engine” and boasting 5.5 litres of displacement while combining high-tech components such as direct petrol injection with piezo injectors including a fully variable injection pressure of 100–200 bar. In a plentiful torque curve up to 900 Nm are available between 2250–3750 rpm. The maximum output is 430 kW (585 hp). The Mercedes-AMG SL 63 accelerates from 0 to 100 km/h in 4.1 seconds. The Mercedes-AMG SL 65 is driven by an AMG 6.0-litre V12 biturbo engine and boasts superior performance, generating 463 kW (630 hp) and 1000 Nm from 2300–4300 rpm.



Braking system.

Excellent deceleration values are achieved by the optional AMG ceramic high-performance compound braking system with perforated and internally ventilated brake discs featuring “AMG Carbon Ceramic” lettering on the bronze-coloured brake callipers. It possesses a higher degree of hardness and has approximately 40 percent less weight. Even under maximum stress, such as use on the race track, the braking performance remains constantly high.





Passion grows when it is shared: the AMG Private Lounge is our community centred around the world of AMG. This is where AMG customers meet at top-class events and on the online platform exchange views about the latest developments from Affalterbach. They benefit from special offers and from a direct connection with the AMG headquarters: www.mercedes-amg.com/privatelounge/welcome

The AMG Driving Academy stands for an incomparable team spirit: experience performance with like-minded drivers and improve your driving skills on race tracks and at lifestyle events held at breathtaking locations around the world. Become part of the “World’s Fastest Family”: www.mercedes-amg.com/driving-academy

You want even more? With the AMG Customer Sports Programme AMG provides a platform for professional motorsport – and with the Mercedes-AMG GT3 its own racing car specially designed for this purpose. A completely integral service world gives you access to motorsport at the highest level: www.mercedes-amg.com/customersports

In the AMG Performance Studio we create cars that are perfectly tailored to your wishes and desires. No limits are placed on our experts’ creativity, who demonstrate their unparalleled craftsmanship and attention to detail in areas as varied as special technical components, extravagant paintwork finishes and the most exclusive interior appointments imaginable, to produce one-off masterpieces.

Enter the world of AMG. Experience Driving Performance.

We don't just build cars.
We make dreams come true.

Technical data.

	SL 400	SL 500
No. of cylinders/arrangement	6/V	8/V
Total displacement in cc	2996	4663
Rated output ¹ in kW (hp) at rpm	270 (367)/5500–6000	335 (455)/5250
Rated torque ¹ in Nm at rpm	500/2000–4200	700/1800–3500
Transmissions	9G-TRONIC	9G-TRONIC
Acceleration from 0 to 100 km/h in sec.	4.9	4.3
Top speed, approx. in km/h	250 ²	250 ²
Tyre size – front axle, rear axle	255/40 R 18, 255/40 R 18	255/40 R 18, 285/35 R 18
Fuel	Super Plus petrol	Premium petrol
Fuel consumption ³ in l/100 km		
Urban	10.5	12.4
Extra-urban	6.0	7.0
Combined	7.7	9.0
CO ₂ emissions ³ in g/km combined	175	205
Emission class ⁴ /efficiency class ⁵	Euro 6/D	Euro 6/E
Tank capacity, of which reserve, approx. in l	65/8.0	65/8.0
Luggage compartment capacity in l		
With the roof closed	485	485
With the roof open	345	345
Turning circle diameter in m	11.04	11.04
Kerb weight ⁶ in kg	1735	1795
Perm. GVW in kg	2115	2175
Length ⁷ /width incl. mirrors ⁷ in mm	4631/2099	4631/2099
Wheelbase ⁷ in mm	2585	2585
Track width, front ⁷ /rear ⁷ in mm	1597/1600	1597/1600

The best for the engine:
Mercedes-Benz genuine engine oils.

¹ Figures for rated output and rated torque in accordance with Directive (EC) no. 595/2009 in the currently applicable version. ² Electronically governed. ³ The figures shown for fuel consumption and CO₂ emissions were obtained in accordance with the prescribed measuring processes (§2 nos. 5, 6, 6a of the German Ordinance on Fuel Consumption Labelling (EnVKV) in the currently applicable version). The figures are not based on an individual vehicle and do not constitute part of the product offer; they are provided solely for purposes of comparison between different vehicle models. ⁴ Valid only within the European Union. ⁵ Determined on the basis

	Mercedes-AMG SL 63	Mercedes-AMG SL 65
No. of cylinders/arrangement	8/V	12/V
Total displacement in cc	5461	5980
Rated output ¹ in kW (hp) at rpm	430 (585)/5500	463 (630)/4800–5400
Rated torque ¹ in Nm at rpm	900/2250–3750	1000/2300–4300
Transmissions	AMG SPEEDSHIFT MCT 7-speed sports transmission	AMG SPEEDSHIFT PLUS 7G-TRONIC
Acceleration from 0 to 100 km/h in sec.	4.1	4.0
Top speed, approx. in km/h	250 ²	250 ²
Tyre size – front axle, rear axle	255/35 ZR 19, 285/30 ZR 19	255/35 ZR 19, 285/30 ZR 20
Fuel	Super Plus petrol	Super Plus petrol
Fuel consumption ³ in l/100 km		
Urban	14.2–14.0	17.4
Extra-urban	7.7–7.5	8.8
Combined	10.1–9.8	11.9
CO ₂ emissions ³ in g/km combined	234–229	279
Emission class ⁴ /efficiency class ⁵	Euro 6/F	Euro 6/G
Tank capacity, of which reserve, approx. in l	75/10	75/10
Luggage compartment capacity in l		
With the roof closed	504	504
With the roof open	364	364
Turning circle diameter in m	11.04	11.04
Kerb weight ⁶ in kg	1845	1950
Perm. GVW in kg	2180	2210
Length ⁷ /width incl. mirrors ⁷ in mm	4640/2099	4640/2099
Wheelbase ⁷ in mm	2584	2584
Track width, front ⁷ /rear ⁷ in mm	1621/1604	1621/1605

of the measured CO₂ emissions taking into account the mass of the vehicle. ⁶ Figures for kerb weight in accordance with Directive 92/21/EC in the currently applicable version (kerb weight with fuel tank 90% full, driver, 68 kg, and luggage, 7 kg) for standard-specification vehicles. Optional extras and accessories will generally increase this figure and reduce the payload capacity accordingly. ⁷ The dimensions given are mean values. They apply to unladen standard-specification vehicles. Further technical data can be found at www.mercedes-benz.com

Dimensions.

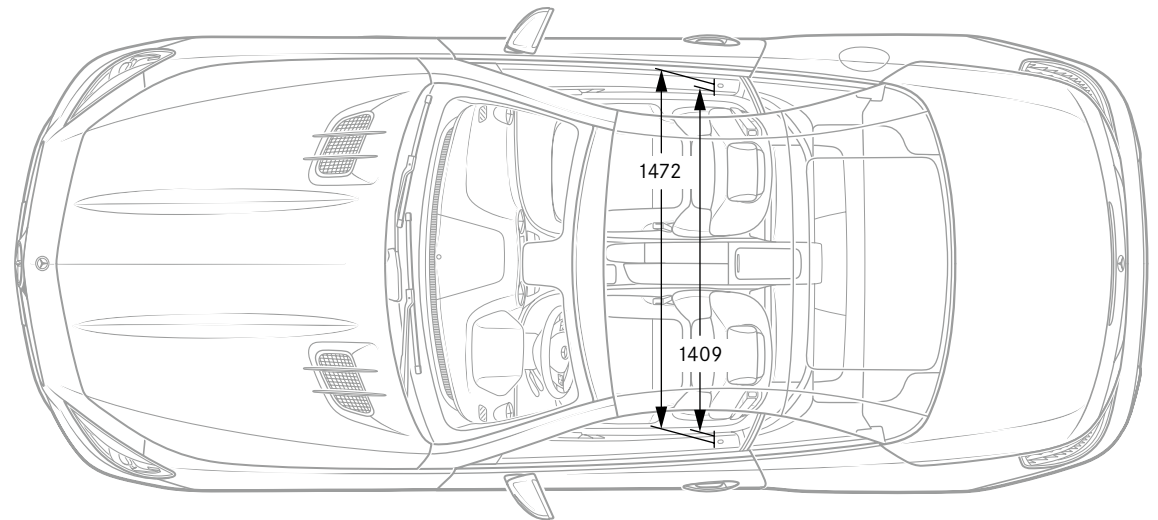
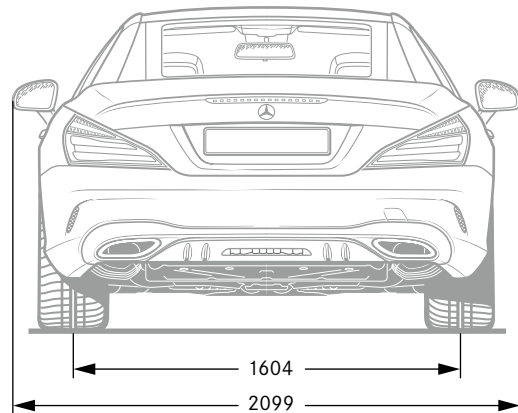
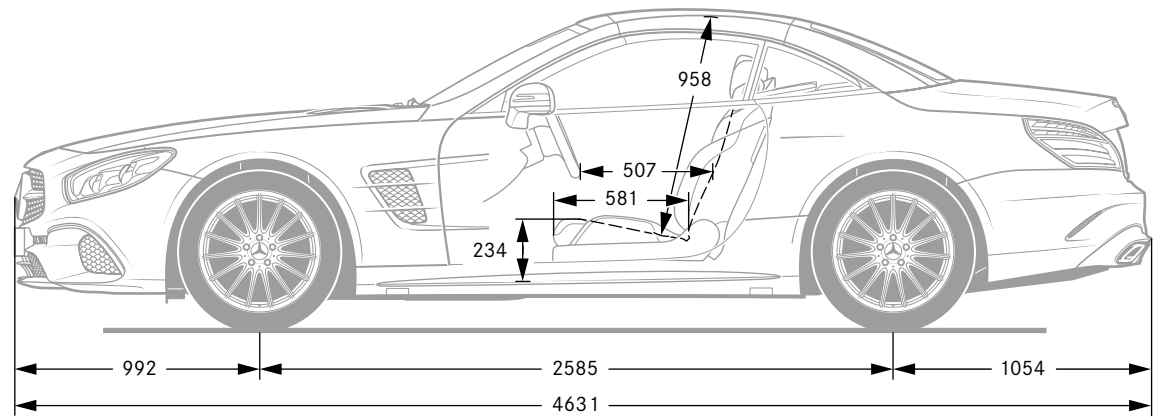
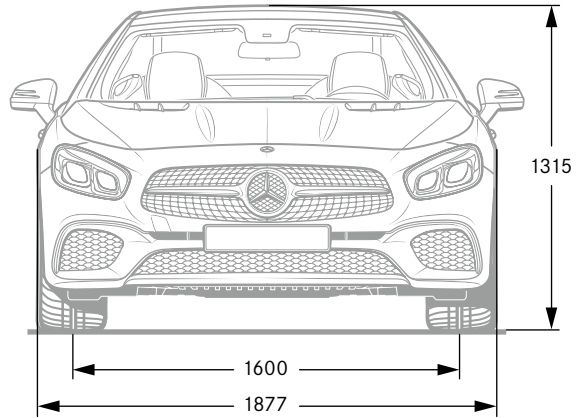

All dimensions in millimetres. The dimensions shown are mean values and apply to standard-specification, unladen vehicles.

Upholstery and trim.

Upholstery

201	black ^{1,2}
205	ginger beige/espresso brown ^{1,2}
207	bengal red/black ^{1,2}
211	black ^{1,3}
218	crystal grey/black ^{1,2}
501	black ^{1,6}
505	ginger beige/espresso brown ^{1,6}
507	bengal red/black ^{1,6}
511	black ^{5,6}
514	saddle brown/black ¹
515	porcelain/black ^{1,6}
701	black
801	black ^{1,4}
805	ginger beige/espresso brown ^{1,4}
807	bengal red/black ^{1,4}
811	black ^{4,5}
814	saddle brown/black ¹
815	porcelain/black ^{1,4}
X10	designo sand/black ^{1,7}
X17	designo classic red/black ^{1,7}
X18	designo tuscan beige pearl/black ^{1,7}
X24	designo sienna brown/black ^{1,7}
X26	designo titanium grey pearl/black ^{1,7}
X30	designo platinum white/black ^{1,7}
X35	designo light brown/black ^{1,7}
X46	designo deep white/black ^{1,7}

Trim

739	Light longitudinal-grain aluminium
729	Light brown satin-finish poplar wood ¹
731	High-gloss brown burr walnut wood ²
736	High-gloss black ash wood ¹
H42	Light carbon-grain aluminium ¹
H73	AMG carbon fibre ^{1,4,6}
H76	Dark longitudinal-grain aluminium ^{1,5}
W26	designo natural bamboo ¹
W69	designo black piano lacquer ¹
W70	designo champagne white piano lacquer ¹

Leather/fabric



Leather



¹ Optional extra. ² Standard for SL 500, optional extra for SL 400. ³ Part of the AMG Line for SL 400 and SL 500. ⁴ Standard for Mercedes-AMG SL 63. ⁵ Optional extra for SL 400 and SL 500 in conjunction with AMG Line. ⁶ Standard for Mercedes-AMG SL 65. ⁷ Building on nappa leather or Exclusive nappa leather.

Nappa/Exclusive nappa leather

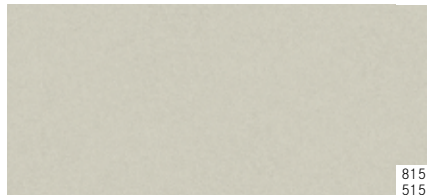

designo leather/designo Exclusive leather

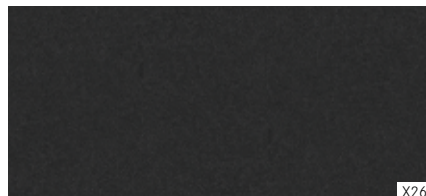

Trim

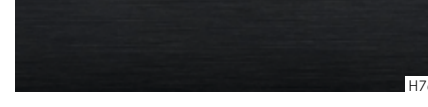

designo trim



Paintwork.

Non-metallic paints



040

Metallic paints¹



183



775

designo paints¹



297

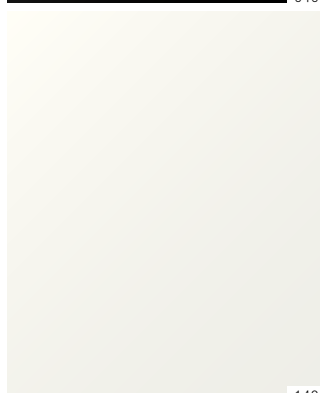

149



197



896



799



590



526



992



996

Non-metallic paints

- 040 black
149 polar white
590 fire opal
-

Metallic paints¹

- 183 magnetite black
197 obsidian black
526 dolomite brown
775 iridium silver
896 brilliant blue
992 selenite grey
-

designo paint finishes¹

- 297 designo selenite grey magno
799 designo diamond white bright
996 designo hyacinth red metallic
-

¹ Optional extra.



Mercedes-Benz is one of the founding partners of the “Laureus Sport for Good Foundation”.

Since the foundation was established in 2000, Mercedes-Benz has been supporting and promoting the aims and values of this worldwide non-profit-making programme: to use social sports projects to improve the lives of children and young people who are disadvantaged or suffering from illness. Laureus has become a fundamental element of Mercedes-Benz’s social responsibility. Every new Mercedes is an ambassador embodying these values. In buying a Mercedes you are supporting the “Laureus Sport for Good Foundation”.

Please note: changes may have been made to the product since this brochure went to press (13.11.2015). The manufacturer reserves the right during the delivery period to make changes to the design, form, colour or specification, provided these changes, while taking into account the interests of the vendor, can be deemed reasonable with respect to the purchaser. Where the vendor or the manufacturer uses symbols or numbers to describe an order or the subject of an order, no rights may be derived solely from these. The illustrations may show accessories and optional extras which are not part of standard specification. Actual colours may differ slightly from those shown owing to the limitations of the printing process. This brochure is distributed internationally. Information given regarding statutory regulations, legal requirements and taxation and the consequences thereof applies to the Federal Republic of Germany only and is correct at the time of going to press. For current and more specific information in relation to the range of models, features, optional extras, colours and/or services available in your country, and their pricing, you should contact your nearest authorised Mercedes-Benz Passenger Car Dealer.

www.mercedes-benz.com

Take-back of end-of-life vehicles. At the end of its long life, you can return your SL to us for environment-friendly disposal in accordance with the European Union (EU) End-Of-Life Vehicle Directive. But that day lies a long way off.

A network of vehicle take-back depots and dismantlers has been established to make it as easy as possible for you to return your vehicle. You can leave it at any of these points free of charge and, by so doing, make an important contribution to completing the recycling process and conserving resources.

For further information about the recycling and disposal of end-of-life vehicles, and the take-back conditions, please visit the national Mercedes-Benz website.